

CLASSIFICATION
TO FIRE
B s2 d0



HIGH RESISTANCE
IN A BLINK OF AN EYE



RURAL



INDUSTRIAL



COMMERCIAL



RESIDENTIAL



OPAQUE



TRANSLUCENT



NEW SHEETS MORE RESISTANT THAT REMAIN TRANSPARENT FOR MORE TIME

Relon[®] sheets are formed by polyester resin and reinforced with fiberglass in the form of reinforcement or mesh in order to obtain maximum performance in mechanical properties.

In the upper part, the gelcoat includes a stabilizing treatment to the U.V. which reduces the yellowing index and thus contributes to the passage of light for a longer time.

Relon[®] FR (Fire retardant) sheets contain excellent fire retardant properties that prevent the spread in case of fire.

Applications

- Translucent and opaque covers
- Sheet metal or panel covers for industrial Building
- Fiber cement roofing
- Industrial ships
- Sports and commercial centers

Main advantages

- Very high mechanical properties
- Easy installation
- Wide range of solutions
- Does not suffer strong dilatations
- High chemical resistance
- High mechanical resistance
- High impact resistance
- Good light transmission



Characteristics

General properties

Translucent and profiled **Relon**[®] sheets comply with product standard EN 1013.

THICKNESS RANGE
1.0 - 1.3 mm
Identified with colored threads

(*) consult **Stabilit Europa** our range of thicknesses.

Technical properties for Relon[®] in thickness 1.0 mm

PROPERTIES	RULE	VALUE
Thickness	EN 1013	1.0 mm
Light transmission	EN ISO 13468-1	Transparent: 76%
Linear thermal expansion coefficient	EN 1013	$3 \times 10^{-5} \text{ K}^{-1}$ (0,03 mm/m°C)
Permeability to water vapor	EN 1013	$1,5 \times 10^{-5} \text{ mg/m h Pa}$
Flexural strength	EN 14125	190 MPa
Tensile strength	EN ISO 527-4	150 MPa
Barcol hardness	EN 59	40 - 45
Reaction to fire	EN 13501-1	E
Impact resistance of a large soft body (1200 Joules)	XP P 38-505	According (in thickness ≥ 1.2 mm. Consult profiles that are in accordance with the test)

Relon FR (Fire Retardant): Reaction to fire certificate according to EN 13501-1.
Classification obtained: **B s2 d0**. On request.
Consult with commercial area.



Behaviors to chemical products

Its high resistance to chemical agents provides an excellent performance against corrosion, resisting the acid atmospheres (hydrochloric, phosphoric, sulfuric, nitric), the basic ones, the salts, saline solutions, hydrocarbons, alcohols, etc. Does not resist certain organic solvents or certain acids or concentrated bases. By its nature, it does not form galvanic pairs with fixations.

Installation

Distance between purlins

The maximum separation between purlins must be determined for each profile, depending on the load to be supported and the maximum deformation admissible according to the application (consult the **Stabilit Europa** technical services in each case). The recommended maximum distance between purlins will be 1.50 m.

Long length sheets

For sheets over 6 m in length, with low-wave fixings and self-tapping screws, extreme care must be taken to allow the plate to freely expand (drilling diameter, about 2 mm more than the screw body).

Flight length of sheet

The flight length in the eaves will not be greater than 200 mm, reinforcing in this case its fixation on the lower purlin.



Overlaps

The lateral overlaps have to be opposite to the direction of the wind and rain.



Security

Do not step directly on the sheets, they are not passable and if necessary, do it on light wooden boards, scaffolding, etc., to avoid damaging the product and increase the safety of the operators.



Fixings

The fixings can be made by means of hooks, Solomon screw or self-tapping screws. With self-tapping screws and trapezoidal foils, valley fixation can be carried out, in other cases it must be carried out on a crest.

In the case of crest fixing, a support plate (made of expanded or metallic polystyrene) should be provided between the belt and the sheet. The longitudinal covering ribs must be fixed on all purlins.

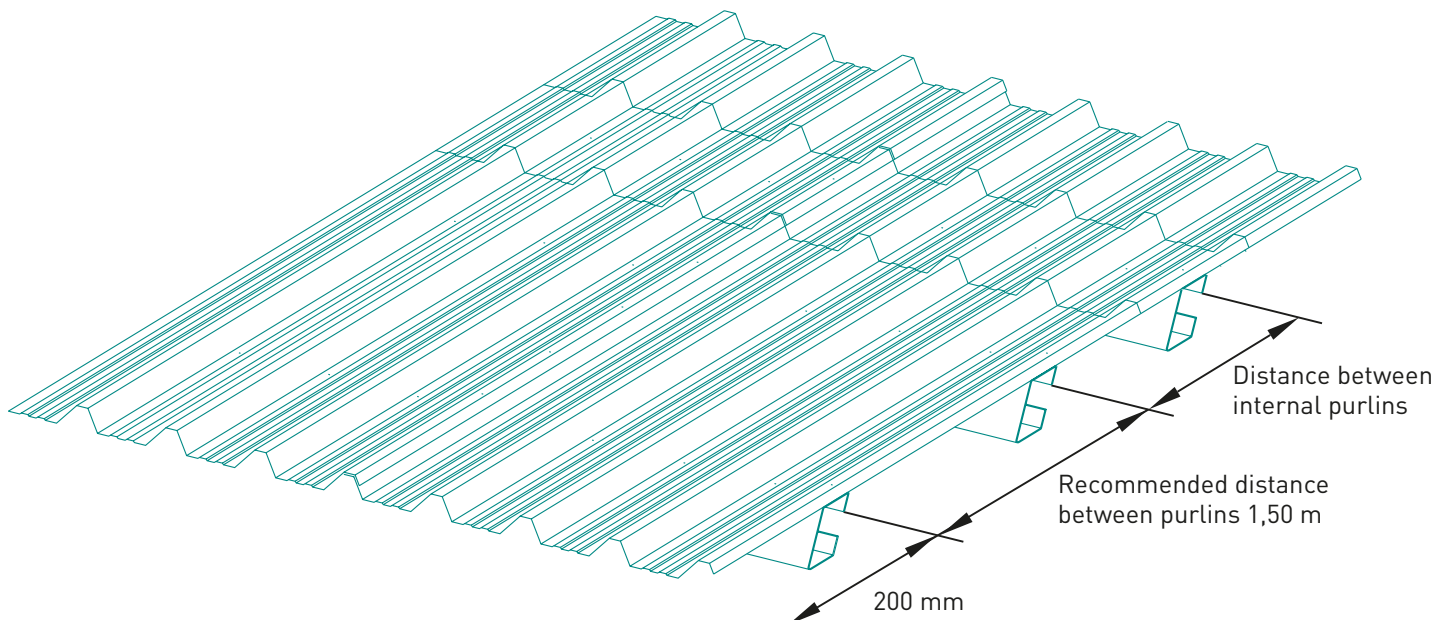

The sheets must be fixed on all the crests on the end supports and can be fixed to the staggered in the intermediate ones. Likewise all nerves must be fixed on the penultimate purlin before the ridge or eaves as well as on all the straps in exposed situations. The fixing points must be symmetrical. The holes for the passage of fixings must be made at a minimum distance of 50 mm from the edges of the sheets.

Crest fixation

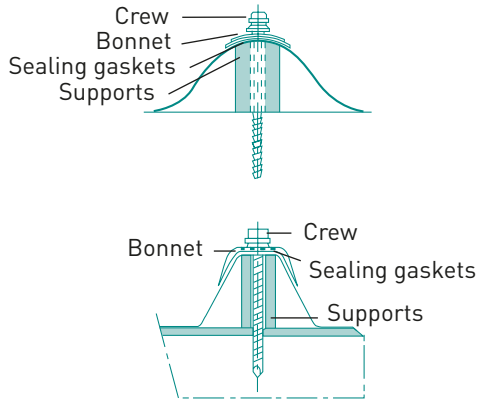

Fixation in valle

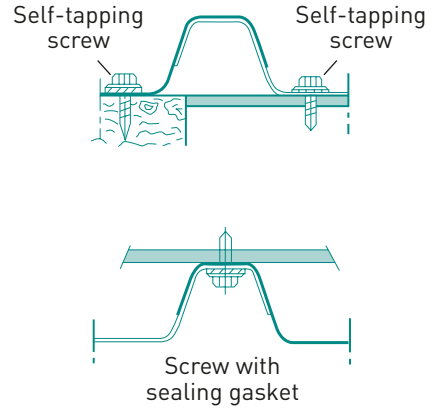

HOW NOT TO
FIX THE SCREWS

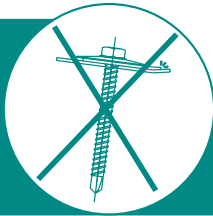

Permissible load



The following graph shows the theoretical capacity of maximum permissible load uniformly distributed for a maximum deformation of $L/100$ on a sheet located between 2 supports at different distances between purlins.

Stabilit Europa recommends that the maximum distance between supports does not exceed 1.5 m.

The maximum permissible load does not represent the breaking load of the sheet, nor can it be extrapolated in the load capacity at a specific point of the same (point load), since the information refers to the uniformly distributed load.

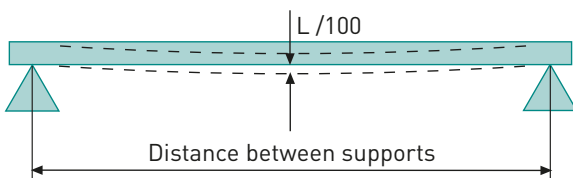

Maximum allowable load for arrow = L/100

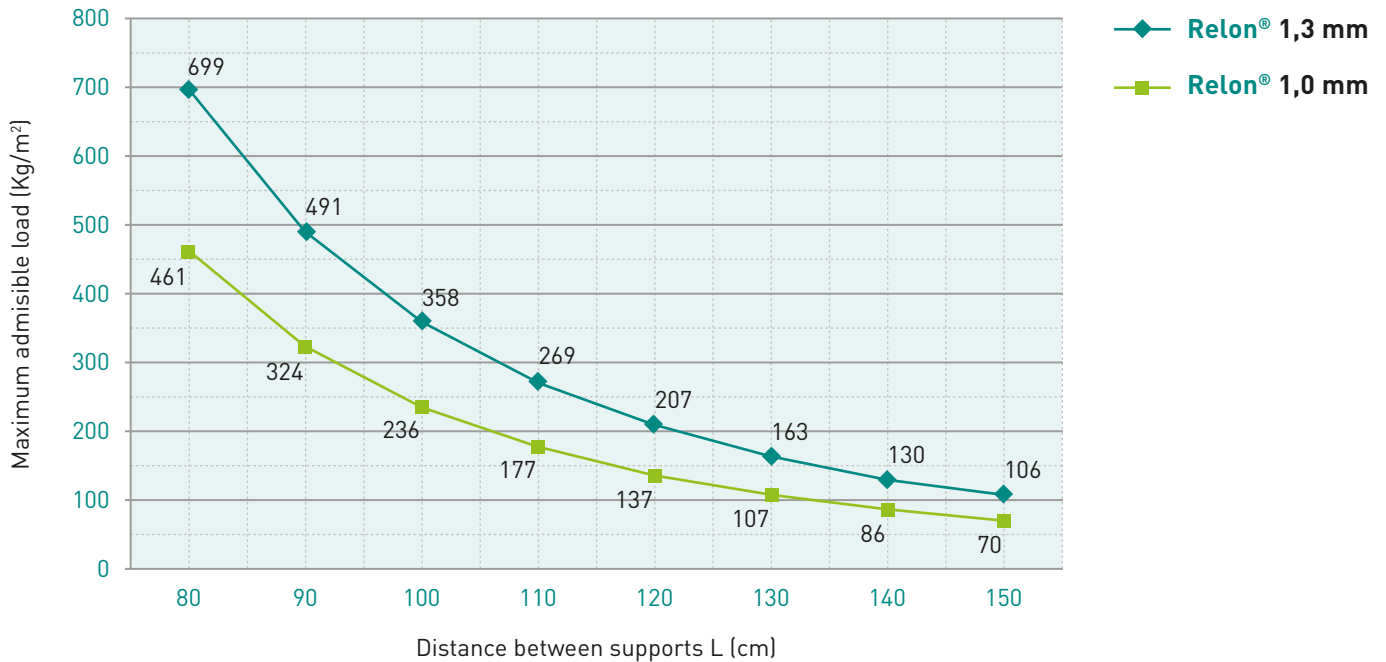

Consult diagram of loads of a profile and concrete thickness to **Stabilit Europa**.

Standard color range

TRANSLUCENT

- Transparent
- Intense green and pale green
- White opal
- Intense blue and pale blue

Other colors: consult **Stabilit Europa**.

Standard thickness range

- 1.0 mm
- 1.3 mm

Standard range of profiles

STANDARD PROFILES

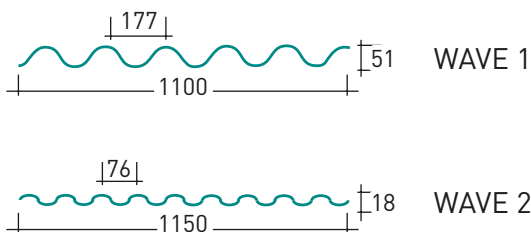

TRAPEZIODAL PROFILES

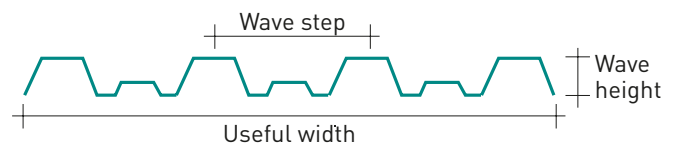

* Different profiles adaptable to any type of metal sheet or fiber cement.

Other profiles: consult **Stabilit Europa**.



Certifications

Stabilit Europa is distinguished by having the Quality Management System certification according to the ISO 9001 standard in all its processes.

Fire reaction certificate in **Relon**® product according to EN 13501-1. Classification obtained: E.

Fire reaction certificate in **Relon**® FR product according to EN 13501-1. Classification obtained: B s2 d0. (On request).

Impact test certificate 1200 J in **Relon**® product.

Distributor

The information included in the catalog is purely indicative, based on the experience and tests carried out by the company; without this supposes any type of responsibility on his different applications, since **Stabilit Europa** does not have any control on his final use.



Stabilit Europa, s.l.u.

Ctra. de Ripollet B-141, km 3,9
Pol. Ind. Santiga · Apartado 16

08130 Santa Perpètua de Mogoda (Barcelona) Tel.: +34 93 729 00 90 - Fax: +34 93 729 06 43 info@stabiliteuropa.com www.stabiliteuropa.com

Customer Service

Phone 902 194 881

Fax 93 729 06 55 - 93 729 13 51